

# Radial Leads/SkyCap®/SR Series



## GENERAL INFORMATION

**AVX SR Series**

**Conformally Coated Radial Ledged MLC**

**Temperature Coefficients:** C0G (NP0), X7R, Z5U

**200, 100, 50 Volts (300V, 400V & 500V also available)**

**Case Material:** Epoxy

**Lead Material:** RoHS Compliant, 100% Tin

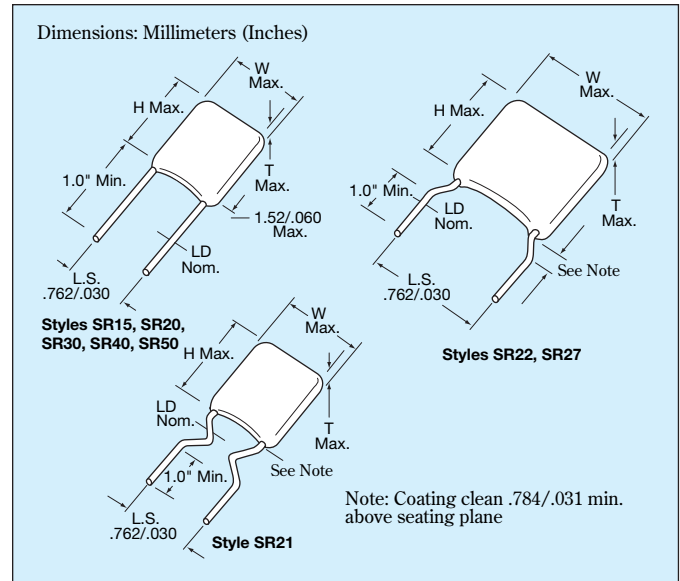

## HOW TO ORDER

<b>SR21</b>	<b>5</b>	<b>E</b>	<b>104</b>	<b>M</b>	<b>A</b>	<b>R</b>
<b>AVX Style</b>	<b>Voltage</b>	<b>Temperature Coefficient</b>	<b>Capacitance</b>	<b>Capacitance Tolerance</b>	<b>Failure Rate</b>	<b>Leads</b>
SR15 SR20 SR21 SR22 SR27 SR30 SR40 SR50	5 = 50V 1 = 100V 2 = 200V 9 = 300V 8 = 400V 7 = 500V	A = C0G (NP0) C = X7R E = Z5U	First two digits are the significant figures of capacitance. Third digit indicates the additional number of zeros. For example, order 100,000 pF as 104. (For values below 10pF use "R" in place of decimal point, e.g., 1R4 = 1.4pF.)	C = ±.25pF D = ±.5pF F = ±1% (>50pF only) G = ±2% (>25pF only) J = ±5% K = ±10%	X7R: J = ±5% K = ±10% M = ±20% Z5U: M = ±20% Z = +80% -20%	A = Not Applicable R = RoHS

## MARKING

**FRONT**

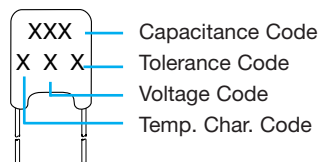

**BACK**

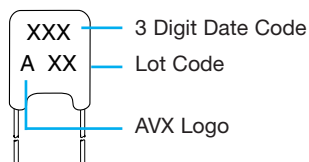

## PACKAGING REQUIREMENTS

	Quantity per Bag
SR15, 20, 21, 22, 27, 30	1000 Pieces
SR40, 50	500 Pieces

Note: SR15, SR20, SR21, SR30, and SR40 available on tape and reel per EIA specifications RS-468. See Pages 33 and 34.

# Radial Leads/SkyCap®/SR Series



C0G (NP0) Dielectric

## SIZE AND CAPACITANCE SPECIFICATIONS

EIA Characteristic

Dimensions: Millimeters (Inches)

AVX Style	SR15	SR20	SR21	SR22	SR27	SR30	SR40	SR50
AVX "Insertable"	SR07	SR29	SR59	N/A	N/A	SR65	SR75	N/A
<b>Width (W)</b>	3.81 (.150)	5.08 (.200)	5.08 (.200)	5.08 (.200)	6.604 (.260)	7.62 (.300)	10.16 (.400)	12.70 (.500)
<b>Height (H)</b>	3.81 (.150)	5.08 (.200)	5.08 (.200)	5.08 (.200)	6.35 (.250)	7.62 (.300)	10.16 (.400)	12.70 (.500)
<b>Thickness (T)</b>	2.54 (.100)	3.175 (.125)	3.175 (.125)	3.175 (.125)	4.06 (.160)	3.81 (.150)	3.81 (.150)	5.08 (.200)
<b>Lead Spacing (L.S.)</b>	2.54 (.100)	2.54 (.100)	5.08 (.200)	6.35 (.250)	7.62 (.300)	5.08 (.200)	5.08 (.200)	10.16 (.400)
<b>Lead Diameter (L.D.)</b>	.508 (.020)	.508 (.020)	.508 (.020)	.508 (.020)	.508 (.020)	.508 (.020)	.508 (.020)	.635 (.025)
<b>Cap. in.* Industry Preferred Values in Blue</b>	<b>WVDC</b> 200 100 50	<b>WVDC</b> 200 100 50	<b>WVDC</b> 200 100 50	<b>WVDC</b> 200 100 50	<b>WVDC</b> 200 100 50	<b>WVDC</b> 100 50	<b>WVDC</b> 100 50	<b>WVDC</b> 100 50
1.0-9.9 <b>10</b> 15	SR151A1R0DAR <b>SR151A100KAR</b> SR.....A150KAR							
22 33 39	SR.....A220KAR SR.....A330KAR SR.....A390KAR							
47 68 <b>100</b>	SR.....A470KAR SR.....A680KAR <b>SR151A101KAR</b>							
150 220 330	SR.....A151KAR SR.....A221KAR SR.....A331KAR							
390 470 680	SR.....A391KAR SR.....A471KAR SR.....A681KAR							
<b>1000</b> 1500 2200	<b>SR211A102KAR</b> SR.....A152KAR SR.....A222KAR							
3900 4700 6800	SR.....A392KAR SR.....A472KAR SR.....A682KAR							
8200 <b>10,000</b> 15,000	SR.....A822KAR <b>SR305A103KAR</b> SR.....A153KAR							
22,000 33,000 39,000	SR.....A223KAR SR.....A333KAR SR.....A393KAR							
47,000 68,000 100,000	SR.....A473KAR SR.....A683KAR SR.....A104KAR							

For other styles, voltages, tolerances and lead lengths see Part No. Codes or contact factory.

\*Other capacitance values available upon special request.

 = Industry preferred values  
 = SR20 only

**NOTE:** Capacitance Ranges available for SR12 same as SR15  
 SR62 same as SR21  
 SR64 same as SR30  
 SR89 same as SR21



# Radial Leads/SkyCap®/SR Series



## X7R Dielectric

### SIZE AND CAPACITANCE SPECIFICATIONS





EIA Characteristic

Dimensions: Millimeters (Inches)

AVX Style	SR15	SR20	SR21	SR22	SR27	SR30	SR40	SR50														
AVX "Insertable"	SR07	SR29	SR59	N/A	N/A	SR65	SR75	N/A														
<b>Width (W)</b>	3.81 (.150)	5.08 (.200)	5.08 (.200)	5.08 (.200)	6.604 (.260)	7.62 (.300)	10.16 (.400)	12.70 (.500)														
<b>Height (H)</b>	3.81 (.150)	5.08 (.200)	5.08 (.200)	5.08 (.200)	6.35 (.250)	7.62 (.300)	10.16 (.400)	12.70 (.500)														
<b>Thickness (T)</b>	2.54 (.100)	3.175 (.125)	3.175 (.125)	3.175 (.125)	4.06 (.160)	3.81 (.150)	3.81 (.150)	5.08 (.200)														
<b>Lead Spacing (L.S.)</b>	2.54 (.100)	2.54 (.100)	5.08 (.200)	6.35 (.250)	7.62 (.300)	5.08 (.200)	5.08 (.200)	10.16 (.400)														
<b>Lead Diameter (L.D.)</b>	.508 (.020)	.508 (.020)	.508 (.020)	.508 (.020)	.508 (.020)	.508 (.020)	.508 (.020)	.635 (.025)														
Cap. in.* pF	Industry Preferred Values in Blue	WVDC			WVDC			WVDC			WVDC			WVDC			WVDC					
		200	100	50	200	100	50	200	100	50	100	50	200	100	50	200	100	50	200	100	50	
470	SR.....C471KAR																					
1000	SR155C102KAR																					
1500	SR.....C152KAR																					
2200	SR.....C222KAR																					
3300	SR.....C332KAR																					
4700	SR.....C472KAR																					
6800	SR.....C682KAR																					
10,000	SR215C103KAR																					
15,000	SR.....C153KAR																					
22,000	SR.....C223KAR																					
33,000	SR.....C333KAR																					
47,000	SR.....C473KAR																					
68,000	SR.....C683KAR																					
100,000	SR215C104KAR																					
150,000	SR.....C154KAR																					
220,000	SR215C224KAR																					
330,000	SR.....C334KAR																					
390,000	SR.....C394KAR																					
470,000	SR305C474KAR																					
1.0 µF	SR305C105KAR																					
2.2 µF	SR405C225KAR																					
2.7 µF	SR505C275KAR																					
4.7 µF	SR505C475KAR																					

For other styles, voltages, tolerances and lead lengths see Part No. Codes or contact factory.

\*Other capacitance values available upon special request.

-  = Industry preferred values
-  = SR20 only
-  = Extended range
-  = Extended range, SR20 only
-  = Extended range with 0.150" thickness maximum

**NOTE:** Capacitance Ranges available for SR12 same as SR15  
 SR62 same as SR21  
 SR64 same as SR30  
 SR89 same as SR21



# Radial Leads/SkyCap®/SR Series



## Z5U Dielectric

### SIZE AND CAPACITANCE SPECIFICATIONS

EIA Characteristic

Dimensions: Millimeters (Inches)

AVX Style	SR15	SR20	SR21	SR22	SR27	SR30	SR40	SR50
AVX "Insertable"	SR07	SR29	SR59	N/A	N/A	SR65	SR75	N/A
Width (W)	3.81 (.150)	5.08 (.200)	5.08 (.200)	5.08 (.200)	6.604 (.260)	7.62 (.300)	10.16 (.400)	12.70 (.500)
Height (H)	3.81 (.150)	5.08 (.200)	5.08 (.200)	5.08 (.200)	6.35 (.250)	7.62 (.300)	10.16 (.400)	12.70 (.500)
Thickness (T)	2.54 (.100)	3.175 (.125)	3.175 (.125)	3.175 (.125)	4.06 (.160)	3.81 (.150)	3.81 (.150)	5.08 (.200)
Lead Spacing (L.S.)	2.54 (.100)	2.54 (.100)	5.08 (.200)	6.35 (.250)	7.62 (.300)	5.08 (.200)	5.08 (.200)	10.16 (.400)
Lead Diameter (L.D.)	.508 (.020)	.508 (.020)	.508 (.020)	.508 (.020)	.508 (.020)	.508 (.020)	.508 (.020)	.635 (.025)
Cap. in.* Industry Preferred Values in Blue	WVDC 100 50	WVDC 100 50	WVDC 100 50	WVDC 100 50	WVDC 100 50	WVDC 100 50	WVDC 100 50	WVDC 100 50
10,000 47,000 100,000	SR15E103ZAR SR.....E473ZAR SR215E104ZAR							
150,000 220,000 330,000	SR.....E154ZAR SR215E224ZAR SR215E334ZAR							
470,000 680,000	SR215E474ZAR SR.....E684ZAR							
1.0 µF 1.5 µF 2.2 µF	SR.....105ZAR SR30E155ZAR SR30E225ZAR							
3.3 µF 4.7 µF	SR30E335ZAR SR30E475ZAR							

For other styles, voltages, tolerances and lead lengths see Part No. Codes or contact factory.

\*Other capacitance values available upon special request.

- = Industry preferred values
- = SR20 only

### AVX 500 VOLT SKYCAPS\*\*

STYLE*	MAXIMUM CAPACITANCE VALUE	
	COG (NP0)	X7R
SR29	900 pF	.015 µF
SR20	1800 pF	.033 µF
SR28 SR59	900 pF	.015 µF
SR13 SR21	1800 pF	.033 µF
SR30 SR61 SR65	7200 pF	.12 µF
SR40 SR75	.015 µF	.27 µF
SR22	1800 pF	.033 µF
SR27	1800 pF	.033 µF
SR76	.015 µF	.27 µF
SR50	.036 µF	.59 µF

\*Consult pages 27 and 28 for style sizes.

\*\*Voltage rating based on DWV of 150% of rated voltage.



## Configurations by Lead Spacing

LEAD SPACING <b>.100 ±.030</b>				Dimensions: Inches (Millimeters)			
<p><b>AR07/SR07*</b> (T=.100)</p>	<p><b>AR14/SR14</b> (T=.100)</p>	<p><b>AR15/SR15*</b> (T=.100)</p>	<p><b>AR20/SR20*</b> (T=.125)</p>	<p><b>AR29/SR29*</b> (T=.125)</p>	<p><b>AR62/SR62*</b> (T=.125)</p> <p>Leads = #22 AWG</p>	<p><b>SR62-LP*</b> (T=.100)</p> <p>Leads = #22 AWG</p>	

LEAD SPACING <b>.200 ±.030</b>					Dimensions: Inches (Millimeters)									
<p><b>AR12/SR12*</b> (T=.100)</p>	<p><b>SR13*</b> (T=.125)</p>	<p><b>AR21/SR21*</b> (T=.125)</p>	<p><b>SR21-85*</b> (T=.125)</p>	<p><b>SR28*</b> (T=.125)</p>	<p><b>AR30/SR30*</b> (T=.150)</p>	<p><b>SR30-LP*</b> (T=.150)</p>	<p><b>AR32/SR32*</b> (T=.150)</p>	<p><b>AR40/SR40*</b> (T=.150)</p>	<p><b>AR59/SR59*</b> (T=.125)</p>	<p><b>SR61</b> (T=.150)</p>	<p><b>SR63*</b> (T=.150)</p>	<p><b>SR64*</b> (T=.150)</p> <p>Leads = #22 AWG</p>	<p><b>SR64-LP*</b> (T=.150)</p> <p>Leads = #22 AWG</p>	<p><b>AR65/SR65*</b> (T=.150)</p>
<p><b>AR30/SR30*</b> (T=.150)</p>	<p><b>SR30-LP*</b> (T=.150)</p>	<p><b>AR32/SR32*</b> (T=.150)</p>	<p><b>AR40/SR40*</b> (T=.150)</p>	<p><b>AR59/SR59*</b> (T=.125)</p>	<p><b>SR61</b> (T=.150)</p>	<p><b>SR63*</b> (T=.150)</p>	<p><b>SR64*</b> (T=.150)</p> <p>Leads = #22 AWG</p>	<p><b>SR64-LP*</b> (T=.150)</p> <p>Leads = #22 AWG</p>	<p><b>AR65/SR65*</b> (T=.150)</p>					
<p><b>SR61</b> (T=.150)</p>	<p><b>SR63*</b> (T=.150)</p>	<p><b>SR64*</b> (T=.150)</p> <p>Leads = #22 AWG</p>	<p><b>SR64-LP*</b> (T=.150)</p> <p>Leads = #22 AWG</p>	<p><b>AR65/SR65*</b> (T=.150)</p>										

\*SL style available in all SR configurations.

## Configurations by Lead Spacing

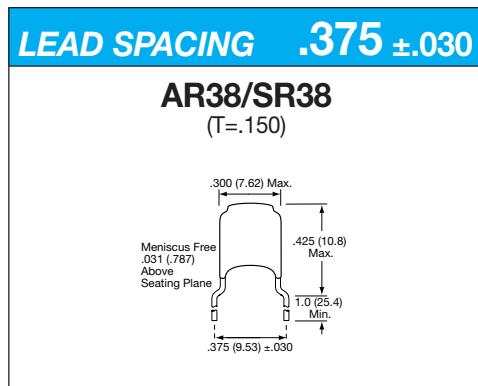
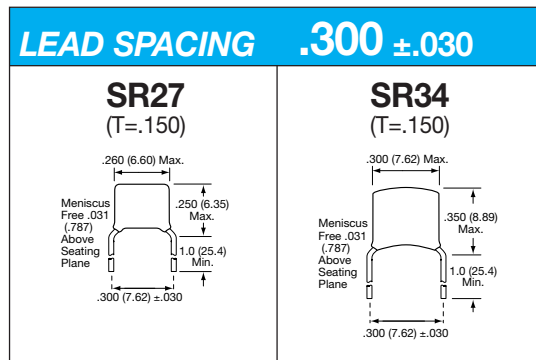
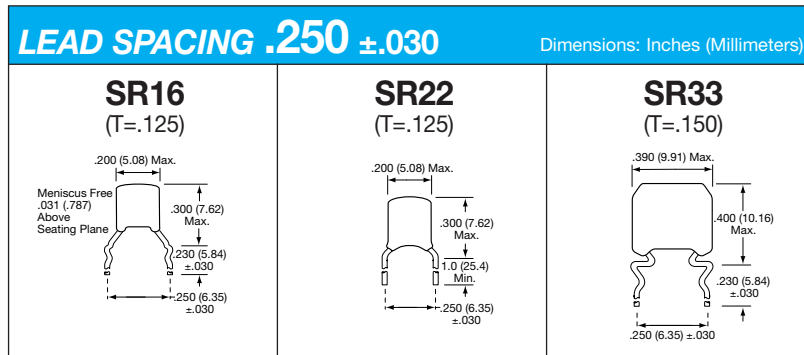

- NOTES:**
1. All leads are #24 AWG unless otherwise noted.
  2. Available in tape and reel packaging(\*).
  3. Other styles are also available, contact factory.
  4. (T = XXX) under type designation is maximum thickness in inches.

\*SL style available in all SR configurations.